

**SANYO**

EM-W3000W

# Microwave Oven

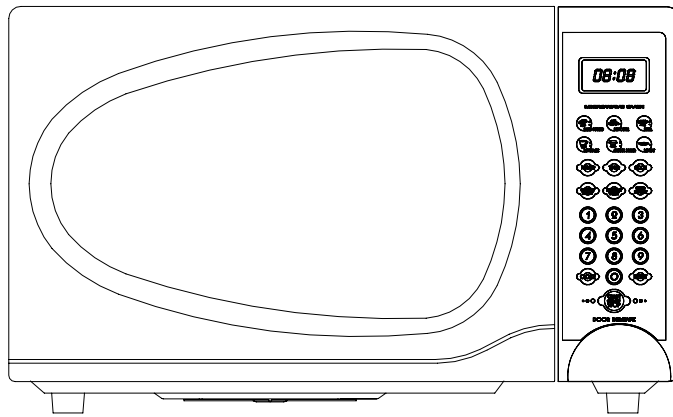

# Service Manual

REFERENCE NO. SM-GA0005

## INTRODUCTION

This Microwave Oven Service Manual is printed in a loose-leaf format. Each part is divided into sections relating to a general group of components and each section is subdivided into various parts describing a particular component or service procedure.

The subdividing of the subject matter plus the loose leaf form will facilitate the updating of the manual as new or revised components and service procedures are introduced.

Each page of this service manual will be identified in the lower right hand corner and, as new or revised pages are published, it will be easy to keep the manual up to date by following the filing instructions on the cover letter.

This Service Manual is a valuable service tool and care should be taken to keep it up to date by prompt and proper filling of subsequent pages as they are issued.

## CONTENTS

SAFETY PRECAUTIONS .....	2
EM-W3000W Microwave Oven Explode Drawing .....	3
EM-W3000W Microwave Oven Parts /Components List.....	4
1. THE HEATING PRINCIPLE OF MICROWAVE .....	5
2. THE STRUCTURE AND WORKING PRINCIPLE OF MICROWAVE OVEN.....	6
2.1    HIGH VOLTAGE RECTIFYING CIRCUIT.....	6
2.2    MICROWAVE GENERATER.....	7
2.3    COOLING SYSTEM.....	7
2.4    ELECTRIC CONTROL SYSTEM.....	7
3. TYPICAL CIRCUIT ANALYSIS OF MICROWAVE OVEN .....	10
4. HOW TO ASSEMBLE AND DISASSEMBLE MICROWAVE OVEN COMPONENTS .....	11
4.1    THE CABINET .....	11
4.2    THE DOOR COMBINATION.....	12
4.3    THE CONTROL PANEL AND THE DOOR RELEASE MECHANISM.....	13
4.4    THE MAGNETRON.....	13
4.5    THE TRANSFORMER.....	14
4.6    THE FAN MOTOR.....	14
4.7    THE CAPACITOR.....	15
4.8    THE DIODE.....	15
4.9    THE TURNTABLE COMBINATIOM.....	16
4.10   THE DOOR SAFTY INTERLOCKS.....	16
THE CONTROL PANEL OF A TYPICAL MICROWAVE OVEN .....	17
5. BREAKDOWN ANALYSIS AND THE MEANS OF OVERHAULING .....	18
5.1    EXAMINING THE BREAKDOWN CAUSES.....	18
5.2    SPOT EXAMINING STEPS OF THE MICROWAVE OVEN .....	18
5.3    REPAIRING METHOD OF SEVERAL BREAKDOWN .....	21
5.4    THE CHARACTERS REQUIREMENTS OF MICROWAVE AFTER IT HAS BEEN REPAIRED .....	22
6. CRITICAL PARTS SERVICING .....	23
6.1    IMPORTANT THINGS TO DO PRIOR TO CRITICAL PARTS SERVICING:.....	23
6.2    Interlock Assembly Replacement and Adjustment.....	23
7. COMMON BREAKDOWN OF MICROWAVE OVEN AND MEANS OF REPAIRING.....	24
SPECIFICATIONS .....	25

**SAFETY PRECAUTIONS**

**PRECAUTIONS TO BE OBSERVED BEFORE AND DURING SERVICING TO  
AVOID POSSIBLE EXPOSURE TO EXCESSIVE MICROWAVE ENERGY**

- A. Do not operate or allow the oven to be operated with the door open.
- B. Make the following safety checks on all ovens to be serviced before activating the magnetron or other microwave source, and make repairs as necessary.
  - (1). Interlock operation
  - (2). Proper door closing
  - (3). Seal and sealing surfaces (arcing, wear, and other damage).
  - (4). Damage to or loosening of hinges and latches.
  - (5). Evidence of dropping or abuse.
- C. Before turning on microwave power for any service test or inspection within the microwave generating compartments, check the magnetron, wave guide or transmission line, and cavity for proper alignment, integrity, and connections.
- D. Any defective or misaligned components in the interlock, monitor, door seal and microwave generation and transmission systems shall be repaired, replaced, or adjusted by procedures described in this manual before the oven is released to the owner.
- E. A microwave leakage check to verify compliance with the Federal performance standard should be performed on each oven prior to release to the owner.

THIS MANUAL, AS WELL AS THE INFORMATION CONTAINED IN IT, IS TO BE USED ONLY BY AN AUTHORIZED SERVICE TECHNICIAN FAMILIAR WITH AND KNOWLEDGEABLE OF PROPER SAFETY AND SERVICING PROCEDURES AND POSSESSING HIGH QUALITY TEST EQUIPMENT ASSOCIATED WITH MICROWAVE AND ELECTRICAL APPLIANCE REPAIR.

ALL INDIVIDUALS WHO ATTEMPT REPAIRS BY IMPROPER MEANS OR ADJUSTMENT SUBJECT THEMSELVES AND OTHERS TO THE RISK OF SERIOUS OR FATAL INJURY.

# EM-W3000W Microwave Oven Explode Drawing

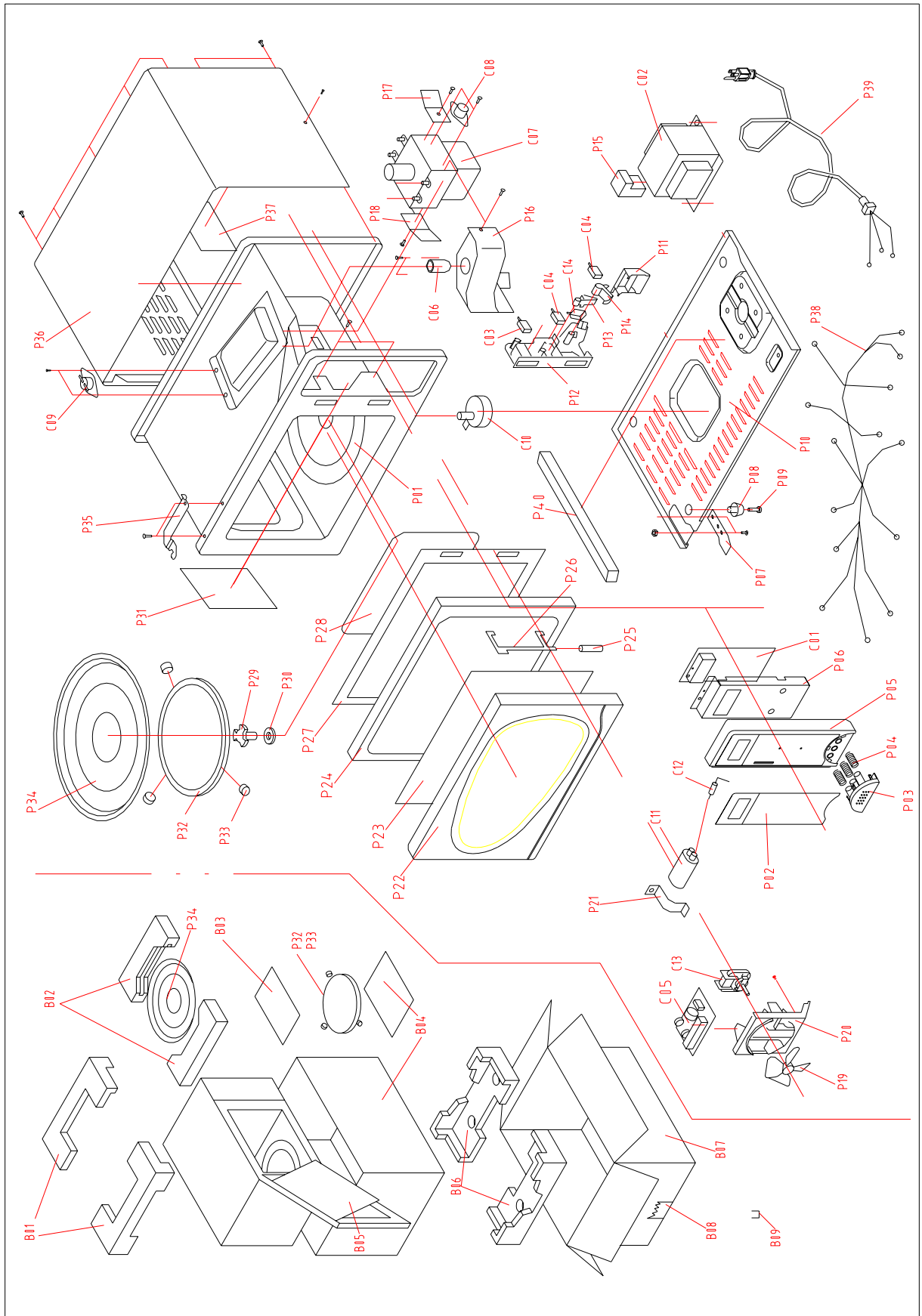

## EM-W3000W Microwave Oven Parts /Components List

PART NO.	PART CODE NO	NAME	QTY	PART NO.	PART CODE NO	NAME	QTY
P01	GA-1000AP30P01	Oven cavity	1	P26	GA-1000AP30P26	Door latch	1
P02	GA-1000AP30P02	Touch key board	1	P27	GA-1000AP30P27	Choke cover	1
P03	GA-1000AP30P03	Door release button	1	P28	GA-1000AP30P28	Inner viewing barrier	1
P04	GA-1000AP30P04	Button spring	2	P29	GA-1000AP30P29	Shaft	1
P05	GA-1000AP30P05	Control panel	1	P30	GA-1000AP30P30	Washer	1
P06	GA-1000AP30P06	PC board holder	1	P31	GA-1000AP30P31	Mica sheet	1
P07	GA-1000AP30P07	Lower hinge	1	P32	GA-1000AP30P32	Roller ring	1
P08	GA-1000AP30P08	Foot	4	P33	GA-1000AP30P33	Ring wheel	3
P09	GA-1000AP30P09	Foot pin	4	P34	GA-1000AP30P34	Glass tray	1
P10	GA-1000AP30P10	Bottom enclosure	1	P35	GA-1000AP30P35	Upper hinge	1
P11	GA-1000AP30P11	Button lever	1	P36	GA-1000AP30P36	Outer enclosure	1
P12	GA-1000AP30P12	Microswitch mounting	1	P37	GA-1000AP30P37	Insulating film	1
		bracket		P38	GA-1000AP30P38	Wire harness	1 set
P13	GA-1000AP30P13	Inner rotary arm	1	P39	GA-1000AP30P39	Power cord	1
P14	GA-1000AP30P14	Outer rotary arm	1	P40	GA-1000AP30P40	Sponge	1
P15	GA-1000AP30P15	Shock proof rubber	2	B01	GA-1000AP30B01	Foam cushion	2
P16	GA-1000AP30P16	Air duct	1	B02	GA-1000AP30B02	Foam cushion	2
P17	GA-1000AP30P17	Wind baffle	1	B03	GA-1000AP30B03	Owner's manual	1
P18	GA-1000AP30P18	Bracket	1	B04	GA-1000AP30B04	Plastic bag	1
P19	GA-1000AP30P19	Fan blade	1	B05	GA-1000AP30B05	Plastic film	1
P20	GA-1000AP30P20	Fan shroud	1	B06	GA-1000AP30B06	Foam cushion	2
P21	GA-1000AP30P21	H.V.capacitor holder	1	B07	GA-1000AP30B07	Carton	1
P22	GA-1000AP30P22	Door frame	1	B08	GA-1000AP30B08	Packing belt	1
P23	GA-1000AP30P23	Door window	1	B09	GA-1000AP30B09	Wrapping nail	12
P24	GA-1000AP30P24	Door	1				
P25	GA-1000AP30P25	Latch spring	1				

COMPONENT NO.	COMPONENT CODE NO.	Name	Model	QTY
C01	GA-1000AP30C01	PC board	GAL9823N-04B	1
C02	GA-1000AP30C02	Transformer	GAL-1000U-1	1
C03	GA-1000AP30C03	Microswitch	V-5230Q or VP533B-OFB	1
C04	GA-1000AP30C04	Microswitch	VP331B-OD	2
C05	GA-1000AP30C05	Fuse socket	FB65	1
C06	GA-1000AP30C06	Oven lamp	KEI T22/125V 20W	1
C07	GA-1000AP30C07	Magnetron	2M248J-N	1
C08	GA-1000AP30C08	Thermostat	KSD180	1
C09	GA-1000AP30C09	Thermostat	KSD105	1
C10	GA-1000AP30C10	Turntable motor	SM012 or M2CJ49Z	1
C11	GA-1000AP30C11	H.V.Capacitor	CH85 1.0 $\mu$ F 2200V	1
C12	GA-1000AP30C12	H.V.Diode	HVM12(450mA)	1
C13	GA-1000AP30C13	Fan Motor	SP-6309-120	1
C14	GA-1000AP30C14	Microswitch	V-5220Q or VP532B-OFB	1
C15	GA-1000AP30C15	Fuse	65TS 125V 20A	1

# 1. THE HEATING PRINCIPLE OF MICROWAVE

Microwave is one kind of radio wave whose wavelength is very short, frequency is very high. Therefore, it is called ultrahigh frequency electromagnetic wave. Microwave can heat food mainly result in the mutual affect of the food in the microwave field and the microwave field itself.

Under the affect of microwave field, the thermal effect mechanism produced from the mutual affect of the microwave and the food includes two aspects. One is Dielectric loss of polar molecule; the other is conductive loss of ion.

Usually, food is constituted of organism (plant and animal). The organism is formed by all kinds of polar water molecule, polar protein molecule, and all sorts of saltion. The center of gravity of the positive and negative charge in the molecule is not coinciding. In normal condition, the molecule is in irregular order due to its thermal action, thus the food do not appear polarity. (FIG.1-1a). Under the action of outer electric field, the positive end of the polar molecule trend to the negative electric field, the negative end of polar molecule trend to the positive electric field, and somewhat arrange in order through the direction of the electric field (FIG.1-1c). This phenomenon usually is called "TORQUE POLARITY". When the outer electric field apply for the opposite polarity, the polar molecule then arrange an opposite direction order accordingly (FIG.1-1b). If the direction of the outer electric field changed repeatedly, the polar molecule would repeatedly sway accordingly. During the swaying, it is understanding that the polar molecule would produce heat due to somewhat similar friction among them. When the electric field is applied for ultrahigh frequent microwave field from the outside, its direction would change tens billion times per second, so do the molecule. This kind of molecule swaying producing similar frictional heat from the interference and block of the action strength among the molecule, and changed to microscopic microwave heating. Microwave heating not only concerned the nature of the matter itself, but also closely connected with the electric strength and frequency. When the frequency is low, the molecule swaying rate and the acute degree of the mutual friction among the molecule is low, and would produce much heat. When the frequency is too high, as the swing of the polar molecule is with rotating inertia, it made the swing do not in line with the changing rhythm of the electric field because of the friction drag, thus, actually lowed the polar molecule swaying speed. The friction dragging degree is concerning about the magnelectric wave frequency, polar molecule shape, and the matter's sticky degree. To different matter's molecule, there is different special frequency zone. Those absorbing microwave energy from this zone are most capable to turn microwave energy to heat energy.

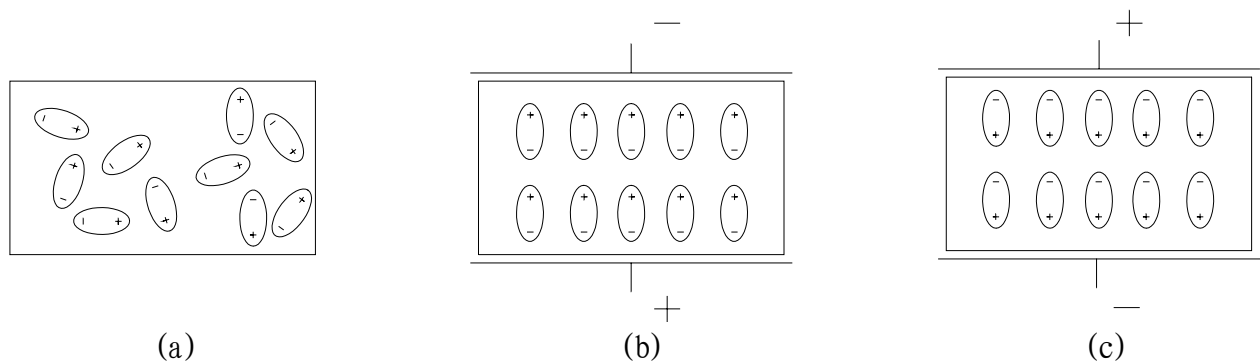

Fig. 1-1

Apart from the above said action, there is another action which is electric ion under the action of microwave field, act fiercely accompanied with the acceleration of electric field. The positive ion transfer to the negative polarity of the field while the negative ion does opposite. Accompanying with the changing electric field, the electric ion hanging accordingly. During the transferring, heat produced with the crash among the ion. This kind of action takes the main effect to those microwaves heating of high salt molecule.

No matter it is the polar molecule swaying or the ion transferring, they both are turning the microwave energy which the heating matter got from the microwave field to heat energy. From the analysis of theory, we can draw such a conclusion that the power which a unit of volume matter absorbed from the microwave field as the following formula:

$$Pa = KE f E t g \delta$$

Pa Stands for the power the heated matter adsorbed from the microwave field.

K Stands for a constant

E Stands for the microwave frequency.

f Stands for the microwave frequency.

$\tan \delta$  Stands for loss angle tangent of the heated matter.

$\epsilon_r$  Stands for relative dielectric constant of the heated matter.

## 2. THE STRUCTURE AND WORKING PRINCIPLE OF MICROWAVE OVEN.

Microwave oven can be classified to many kinds according to various construction, volume and control function. But anyhow, the main electric parts are all composed of high voltage rectification, cooling system. Microwave generator, electric control system and heating chamber (FIG.2-1). Its working process are as follows: 120V power frequency voltage transferred to the rectifier through electric control system, and then be changed to 4000V direct voltage by the rectifier, and be then transferred to the microwave generator, the generator starts working to transfer the microwave energy to the heating chamber for heating food through wave guide tube. At the same time, the electric control system set off the cooling system to cool the working rectifier and the microwave generator to keep the oven working steadily from a too high temperature. If something wrong with the cooling system cause the temperature too high, the control system would cut off the power automatically to prevent microwave generator being damaged from the high temperature. Now, we'd like to introduce the working principle of each part of the widely used model, mechanical control and touch control microwave oven.

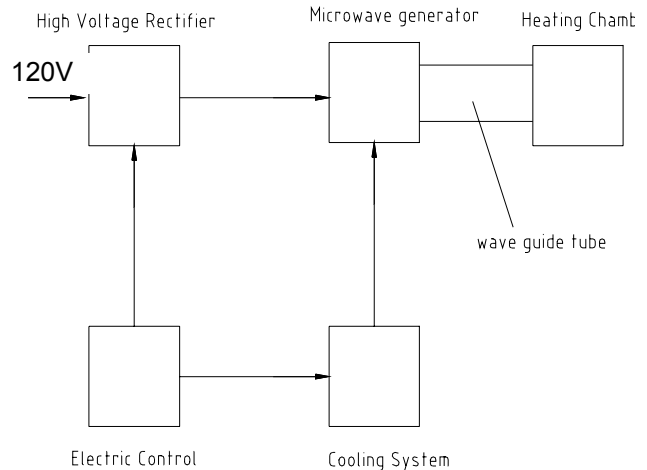

Fig.2-1

### 2.1 HIGH VOLTAGE RECTIFYING CIRCUIT.

At present, home use microwave oven adopt this high voltage rectifying circuit as shown at diagram 2-2. The circuit is a single phase, semi-wave, double voltage rectifying circuit. The circuit has only a high voltage capacitor, a high voltage diode, a magnetic leakage transformer besides the magnetron, is very simple.

The working principle of the circuit: 120V power boosted through the transformer, output about 2000V alternating high voltage current when the high voltage winding is at the positive half-circle, the high voltage winding is at the negative half-circle, the diode is cut off and the magnetron is conducted. The electricity charged at the positive half-circle of the capacitor is series connected with the positive phase of the winding voltage, and got a doubled, about 4000V direct high voltage, then transferred to between the cathode and the anode of the magnetron.

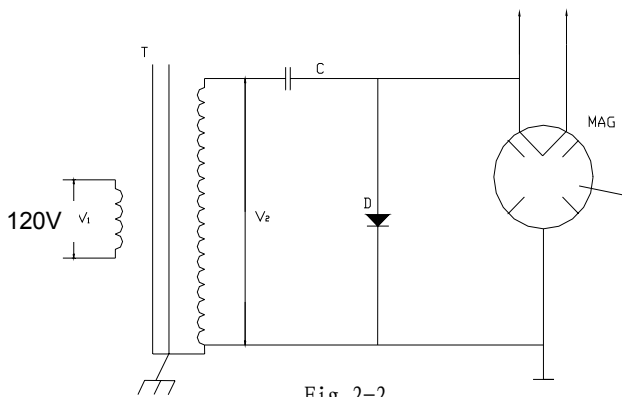

Fig. 2-2

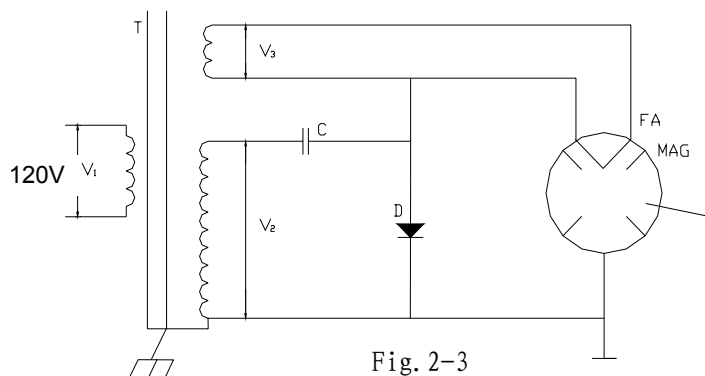

Fig. 2-3

## 2.2 MICROWAVE GENERATOR.

Microwave generator is the heart of microwave oven. The quality of a microwave oven mostly depends on the quality of the microwave generator. A microwave generator is mainly composed of magnetron and its power supply circuit, FIG.2-3 is the typical circuit diagram of the present used microwave oven's generator. The power supply circuit is composed of rectifying circuit and filament circuit.

Usually, we adopt continuous wave magnetron. It can turn the direct energy which is applied to the magnetron after being high voltage rectified to microwave energy, the power supply circuit supply a direct high voltage between the cathode and anode of the magnetron, a filament voltage to the cathode filament of the magnetron.

The working process of the magnetron: When the anode voltage gradually rises from zero, the anode current is approx.zero, the power is very small as well. When the anode voltage rises to "THRESHOLD" voltage value, the magnetron starts oscillating, and the anode current would increase obviously, provided the anode voltage rises a little more, the anode current would increase a lot (FIG.2-4), and would reach the rate value quickly.

If the anode voltage is undulating, it would cause the anode current swing fiercely, even made the magnetron stop oscillating. For keeping a steady output, the power supply circuit of the oven must supply a steady direct current voltage. The filament voltage of the magnetron must be supplied by an alternating current voltage. For simplifying the circuit, it would be supplied by the same leakage magnetic transformer with the anode power (high voltage power). The filament of the magnetron which the present used microwave ovens are all treated through some special technology, and all have the cold start character. But when in cold start, there still is a very strong surge electric field attached to the surface of the anode, and would be harmful to the anode. In order to reduce the surge voltage, the filament of the magnetron must be connected as the FIG.2-3 shown. In this figure, when the anode current of the magnetron circulates, the filament current should flow to the FA end from the lower end.

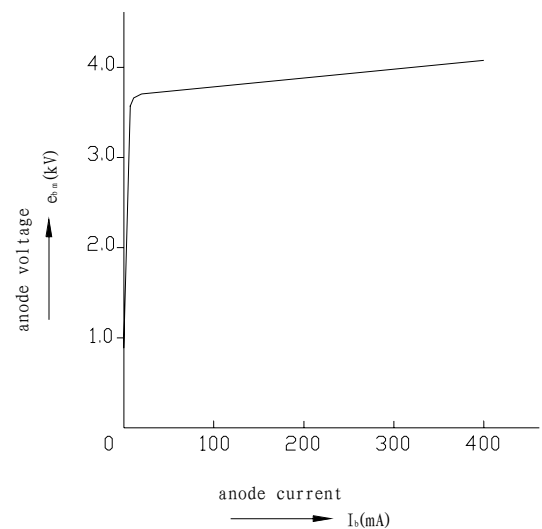

Fig. 2-4

## 2.3 COOLING SYSTEM

In the working process of the microwave oven, the magnetron often makes the anode temperature rise due to anode loss

caused by the electronics strike the oven surface and the heat radiate of the cathode. To prevent the anode temperature rise too high, thus affect the working steady and its life span, it is necessary to cool the magnetron. According to the different models and rate output of the magnetron, compelling wind cooling and flowing water-cooling can be adopted. Usually, the home used microwave oven adopts the compelling wind cooling method, and all are fixed with cooling fin.

Cooling system includes fan motor, air duct, air entrance, air vent etc. The flowing direction of the cooling wind should be parallel to the cooling fin of the magnetron. Generally, we adopt the method of air blast rather than air absorb. And all the cabinet of the oven is with air entrance and air vent, the hot wind blowing through the magnetron is guided with air tube to improve the cooling effect. In the technical parameter chart of the magnetron, it usually will give out the requirement of cooling wind. A shortage of cooling wind would damage the character of the magnetron, even burn out the magnetron. The amount that the fan blasted should not be less than the requirement. When fix the fan, attention must be paid to prevent the cool wind from blowing directly to the glass part of the magnetron to avoid blasting.

## 2.4 ELECTRIC CONTROL SYSTEM.

To those mechanical control microwave oven, electric control system mainly composes of interlock switch, timer, power distributor and thermal cutout, etc. The electric control system of those tough control microwave oven is mainly composed of interlock switch, computer controller and thermal cutout, etc.



### 2.4.1 DOOR INTERLOCK SWITCH

Drawing 2-5(a) is the circuit and construction diagram of the door interlock switch of a microwave oven. It mainly consists of interlock switches (S1, S2), and monitor switch (S3), door hook and starting mechanism of the door interlock switch.

There fixed hooks on the oven door, and opened two rectangle hole at the corresponding place at the right of the oven and the hook. Inside each rectangle hole, there fixed a micro switch. When the oven door closed, the two hook on it would insert into the rectangle hole, and just push down several micro switches. At that time, S1, S2 are closed, S3 is cut off, and the microwave oven is under preparation of working.

To that mechanical control microwave oven, no sooner you turn the time switch to set the heating time than the

power would be supplied to the back to start the oven. To those touch control microwave oven, hardly do you set the heating time and power, and touch the start button when the power would supplied to the back to start the oven.

When pressing down the door release button or pulling the door handle to open the door, the safety interlock switches S1, S2 are cut off, and the monitor switch S3 is closed, and the microwave oven would stop operating immediately. Provided due to some man - made or the appliance itself reasons, when the door is open, and the safety interlock switches S1, S2 are not automatically cut off, due to the existence of the

monitor switch (S3) which is still at conducted condition, the monitor switch would immediately make the 120V voltage short-circuited and blow up the fuse, and will never let the microwave oven working when the door is open.

From this we can understand the function of the interlock switch is when the door is unclosed, the oven wouldn't work, when the door is opened when the oven is working, it would stop the working immediately (FIG.2-5b).

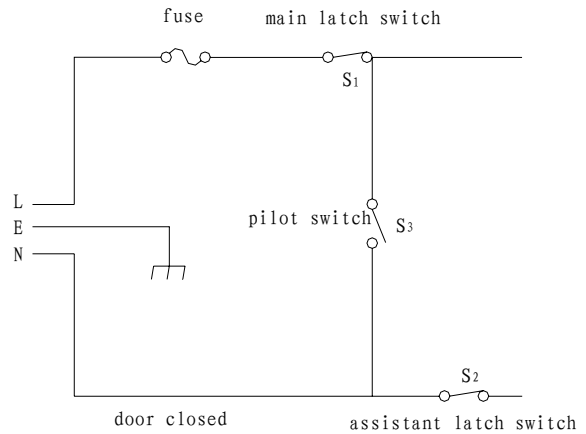

(a)

Fig. 2-5

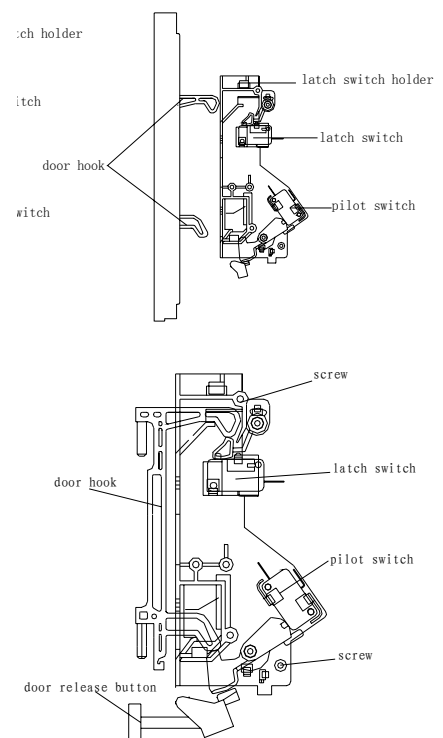

Fig. 2-5 (b)

### 2.4.2 TIME AND POWER DISTRIBUTOR

Time and power distributor is mainly composed of timer motor and two sets of gear switch S4 and S5. When the timer is at zero position, the gear switches are cut off, when the heating time is settled, the gear switch is closed. When started the oven, the time motor starts working. When it reaches the settled time, it would cut off the gear switch (s4) to step the oven working. The gear switch (S5) is designed for controlling the output of the magnetron, actually for controlling the output of the magnetron. It mainly by the method which make the magnetron working internally at the same working point to change the output of the magnetron. This method was called "CONDUCTION RATIO CONTROL". But there is another method which is called "ELECTRIC LEVEL CONTROL" which is through changing the working point (such as anode voltage or magnetic field) to change the output of the magnetron. Because of conduction ratio control method is low cost, high function and high reliability, it is widely used for

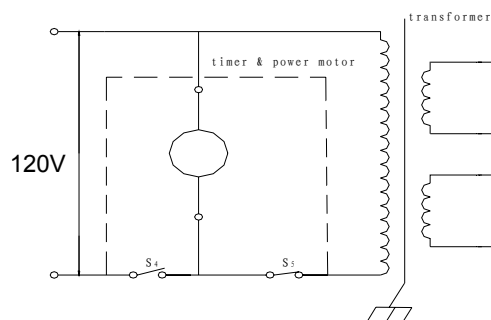

Fig. 2-6

those microwave oven which have the power control function.

FIG.3-1 is the power control circuit diagram of brand microwave oven, WP700. This is a typical instance of conduction ratio control. This oven adopt time and power controller as a whole. When a 120V, 60Hz alternating current is inputted, the time and power motor is always at working condition. At the FIG.2-7, S5 is always conducted. Made the S5 working 30 seconds as a circle, the conduct time can be successively adjusted from 5 seconds to 30 seconds. When power select switch is set at "HIGH", S5 is always conducted, the output of the microwave oven is 700W(full power) when the power select switch is set at defrost position, S5 would conduct for 14.4 seconds, and cut off for 15.5 seconds, and the average output of the oven is 336W.

### 2.4.3 THERMAL CUTOUT

Thermal cutout actually is a thermal sensor switch, usually, it is fixed on the shell of the magnetron, and series connected with the primary circuit of the magnetron to control the power input. At normal condition, the thermal cutout is always conducted (FIG.2-8). When something wrong with the cooling system that cause some abnormal conditions, such as molding or thermal breakdown, which made the temperature of the magnetron reach the limit value. Then, the thermal cutout would work to turn off the power to prevent the magnetron from being damaged.

### 2.4.4 HEATING CHAMBER

Heating chamber is the place where the microwave and the food affect mutually. There are lots kinds of chamber. Accord-ing to the working characters, it can be classified to carton type, cavity type, radiation type, slow type (surface wave type), etc. The present adopt chamber for food cooking microwave oven is the typical carton type heating. (FIG.2-8). The heating chamber is mainly composed of oven door and oven cavity. From the microwave theory, it is a microwave resonant cavity that can contain many kinds of oscillating models simultaneously. Microwave enters into the oven cavity through the wave guide and the coupling appliance, and most of its energy is absorbed by the food after it is reflected in the cavity repeatedly, those which haven't been absorbed will be reflect to the magnetron. A good designed oven cavity should have a good impedance matching with the magnetron, the energy should be less reflect, and distribute evenly in the oven cavity, improve the heating efficiency. Generally, at the same input power, the larger the cavity, the less the energy density a unit volume would have in the oven, and the more energy on the inside wall of the cavity would lose, thence, it would certainly slow down the heating speed, low the heating efficiency. Moreover, too big of the cavity would either waste the material or appears very heavy. The material for cavity usually use non - magnetic stainless steel or zinc - plating steel, and have no high requirements for the conducting rate. The inside coating of the cavity requires beautiful in look, durable when use (should be resistant against damp, heat, acid and alkali), it should also comply with the food health requirements.

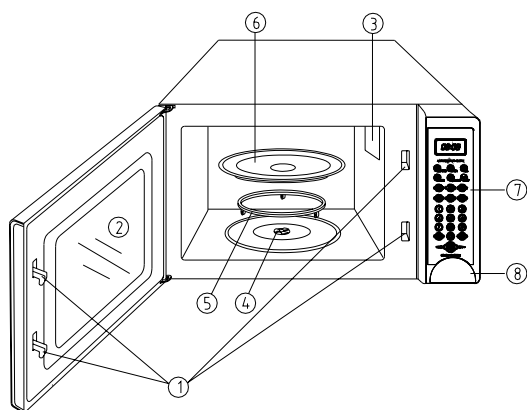

1. Safety interlock switch
2. Door window
3. Air vent
4. Roller Shaft
5. Turntable supporter
6. Glass tray
7. control panel
8. door release button

To improve the heating evenness there often fixed a turntable glass tray at the bottom of the cavity (FIG. 2-8). It is through changing the relative place of the microwave and the heating matter to improve the heating evenness. The turntable tray is usually made of heat – resistant glass, the glass contains some dielectric loss, it can, somewhat, protect the magnetron when the cavity loading less.

There often fixed a dust – proof, low – loss and heat – resistant dielectric cover (such as mica sheet). Sometimes, an impedance matching metal stick was fixed near the coupling or in the wave guide.

The door is designed for inspecting, taking and placing the heating food, it is also one side of the cavity (FIG .2 -

8). It is the most liable place where microwave leakage occurs. Especially, after a long time using, the microwave leakage would enlarge at the hinge and the hook. Anyway, mechanic damage would also cause large amount of microwave leakage. Therefore, the main methods designed for preventing microwave leakage of the door are as follows:

1) Assemble a layer of steel filament or a thin metal plate with many holes at the middle of the window to made it is possible to observe the heating as well as shielding the microwave.

2) The widely used seal measurement at present is to assemble a current – resistant construct between the door and the doorframe. FIG.2-9 is the typical construction fig of the door. It was designed according to the theory of “THE TRANSFERING LINE ONE-FOURTH WAVE LENGTH IMPEDANCE CHANGER”. Although there is no connecting point from a mechanical point. It is sealed at the seam from the point of electricity, so it is called “CURRENT-RESISTANT”. Recently, with the installation of noise filter in the current resistant trough, the effect to restrain the microwave leakage (include high subharmonic) have been much improved.

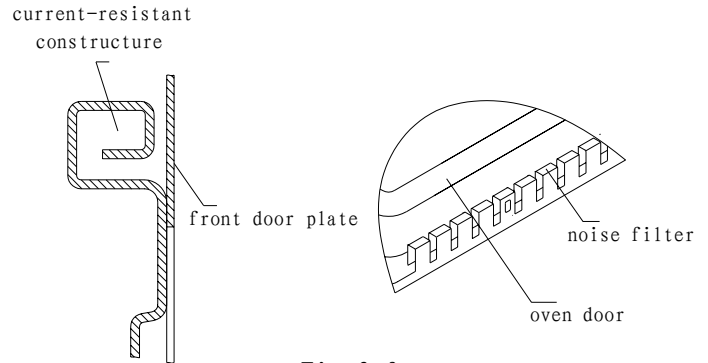

Fig. 2-9

### 3. TYPICAL CIRCUIT ANALYSIS OF MICROWAVE OVEN

We have introduced the structure and the working principle of the microwave oven previously. We shall analyze the complete set circuit of the microwave oven link with the practical circuit at this chapter.

#### SCHEMATIC DIAGRAM

NOTE: Door is closed  
Unit is not operated

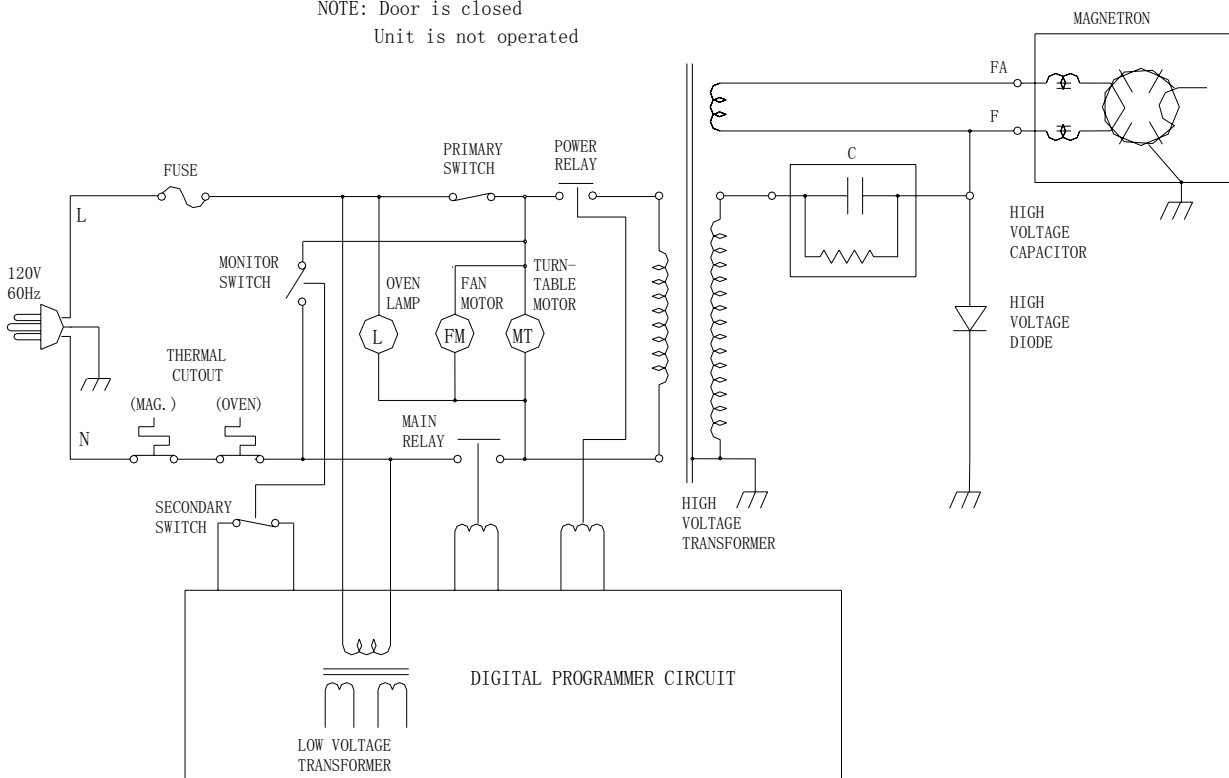

Fig.3–1 is the practical circuit diagram of a microwave oven. Its corresponding working conditions are as follows: The door closed, SW1 and SW2 turned on, SW3 closed, power control relay has no power, R1, R2 is cut off. When cooking, touch the starting switch to power the timer and the power relay. RY1, RY2 closed the power supply to the anode of the magnetron and the filament, changing the power frequency electric energy to microwave energy, the microwave energy then transferred to the heating chamber for food heating. At the same time, the lamp turned on, the fan motor begins to cool the magnetron. The turntable motor set off to drive the food around and making the food heated evenly. The microcomputer begins reckon the time, when it reached the sets time, power relay are cut off, the power of the lamp, all the motor and the magnetron are cut off, the food – heating process ended. During the heating, if the door was opened, the interlock S1, S2 will cut off, S3 will close, all the motors and the magnetron will also be cut off, the lamp will turn on, the oven stop heating immediately. If heating need go on, just push down the starting button and closed the door, the oven will continue its working. When something wrong with the fan motor or the air vent was blocked that breakdown the cooling system, the magnetron temperature would rise high very quickly. When the temperature reached the working point of the thermal cutout (S6), S6 will be cut off immediately to cut off the power supply to the magnetron and the magnetron will stops working right away. The PC board is cut off to prevent the magnetron from being damaged by overheating. When the thermal cutout is cut off, the magnetron, motors and the lamp would stop working simultaneously. Moreover, the thermal cutout has the self - resuming character, when the temperature lowered, it will resume to close condition.

Circuit diagram of computer controlled microwave ovens:

Circuit diagram for mechanical controlled microwave ovens:

## 4. HOW TO ASSEMBLE AND DISASSEMBLE MICROWAVE OVEN COMPONENTS

In the following pages, we will introduce the ways in which the various parts of a typical microwave oven can be disassembled and assembled.

### 4.1 THE CABINET

To disassemble the cabinet

1. Pull out the power plug.
2. Loosen the four screws at the back of the oven with a “+”- screwdriver. (FIG.4-1a)
3. Push the cabinet back 25mm according to the arrow direction shown at FIG.4-1 (b), and the cabinet can be taken off.

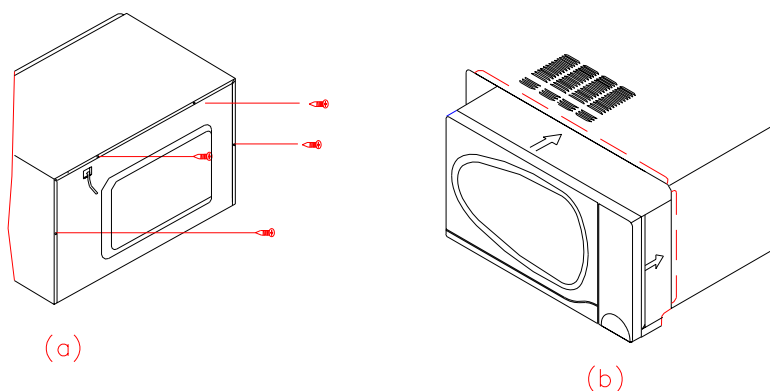

To assemble the cabinet

1. Put the cabinet on the oven, and push it full ahead.
2. Check whether the up, right and left troughs have been inserted with the curved with the curved rim of the oven (FIG.4-1 (b)). If the cabinet and the oven are not tallied exactly, then it should be reassembled or those untallied parts should be smoothed.
3. Tighten those four screws, please make sure that one of the screws should have a plum blossom shape washer to keep a good earth.

## 4.2 THE DOOR COMBINATION

To disassemble,

1. Pull out the power plug.
2. Take off the cabinet.
3. Loosen the two six-angle screws of left hinge (up) with a socket wrench (FIG.4 - 2).
4. Push the door release button to have the hook out (FIG.4 -3).
5. Pull the hinge with the door out of the oven together, and take off the washer of the hinge (low) shaft (FIG.4 - 2).
6. Pick up the ten inverse hooks which around the cover with a small screwdriver carefully(ATTENTION: the cover is made of plastics, and is very liable to be broken), and take out the cover.
7. Take off the two screws at the door side with a "+"-screwdriver
8. Take off the hinge (up)(FIG.4- 2).
9. Apart the doorframe from the doorplate (FIG.4-2).
10. Take off the hook spring with a pointed plier, then the hook combination.
11. Clamp the window plate with hand, push it down according to the arrow direction, and take it off.

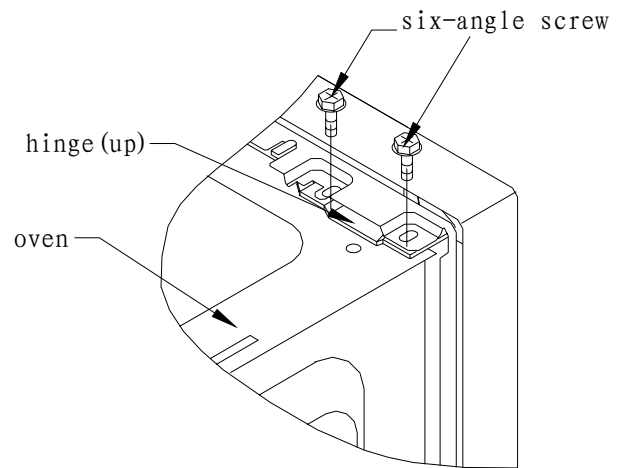

Fig. 4-2

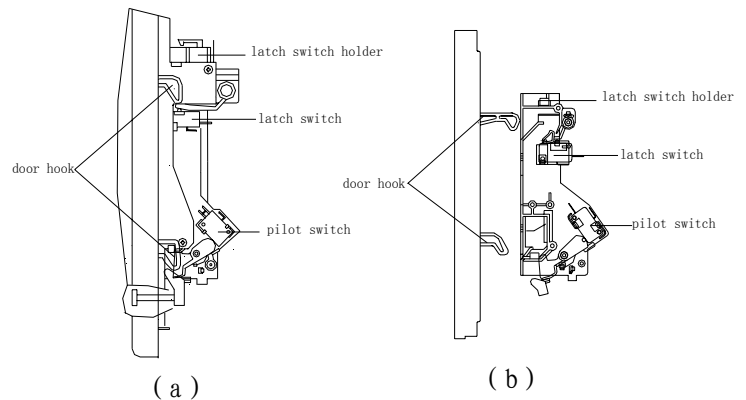

Fig. 4-3

To assemble the door combination(see sketch 4-2 to 4-5)

1. Apply proper silicon grease or lubricating grease on the "★" mark of the hook first, then fix the hook on the oven door, and the spring on its place (FIG.4 - 5), check whether the hook is operating in normal.
2. Apply proper silicon grease or lubricating grease on the "★" mark of the hinge (UP), install the hinge (UP) in the hole at right above of the door as FIG.4 - 2, then install the window on the door as FIG.4 - 1, make sure the hook won't out. Then tighten each hook on the window to the trough of the door. After assembled, check whether the door hook is working in normal.

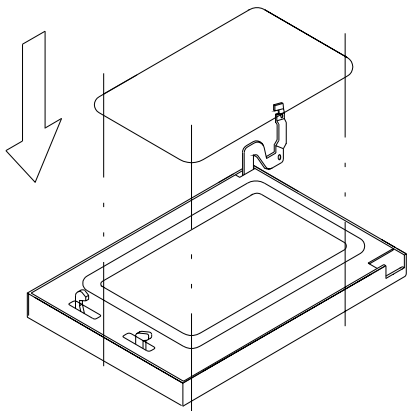

Fig. 4-4

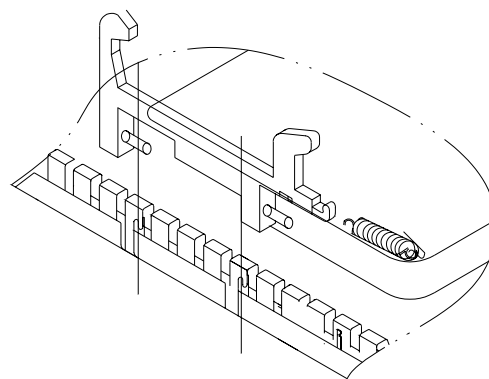

Fig. 4-5

3. Tear off the back protective paper of the window, then the sides of adhesive tape as FIG.4 - 1, and stick it on the window, Tear three right sides protective paper about 10mm, and fix the window in the doorframe as

FIG.4 – 1.

4. Tear off the adhesive protective paper of the lining and stick it on the door as FIG.4 – 1, slip the hook on the doorframe, and fix the doorframe on the door, tighten it with “+” – screws. After assembled, check whether the hook working in normal and whether the hinge (UP) is its position.
5. According to the FIG. 4 –4 shown, paste the inner lining inside the doorframe, make sure it is pasted smoothly, and should have no air bubble.
6. Slip the washer in the hinge shaft, then put the hinge shaft in the hinge hole on the bottom of the oven, the hinge in the rectangle hole on the left above, and hooked it with the door hook.
7. Place a 0.15mm thin paper between the door and the oven, level the door and the oven, then push the door close to the oven, and tighten the two screws of the hinge (UP) and paint them.

#### 4.3 THE CONTROL PANEL AND THE DOOR RELEASE MECHANISM.

1. Pull out the power plug.
2. Take off the cabinet.
3. Discharge between one end of the capacitor and the baseboard with a screwdriver.

To disassemble

1. Pull out the terminal plug of the time and power distributor.
2. Take off the screw which fix the control panel with a “+” – screwdriver (FIG.4 - 6)
3. Take off the control panel.

To assemble,

- (1) Place the two buckles under the control panel into the two rectangle holes under the oven as FIG.4 – 6, then make close of the control panel and the oven with being fixed with a screw. Plug in the terminal plug.

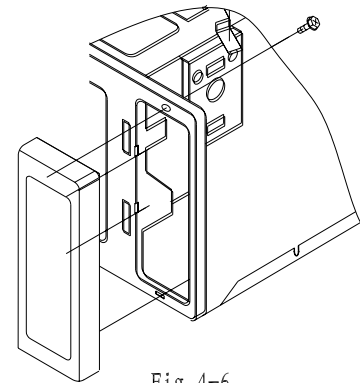

Fig. 4-6

#### 4.4 THE MAGNETRON.

Firstly, do as 1,2,3, steps at III of this part.

To disassemble,

1. Take off the screw beside the oven lamp (FIG.4 - 8).
2. Take out the four screws which fixed the magnetron, and take the magnetron off (FIG.4 - 7).

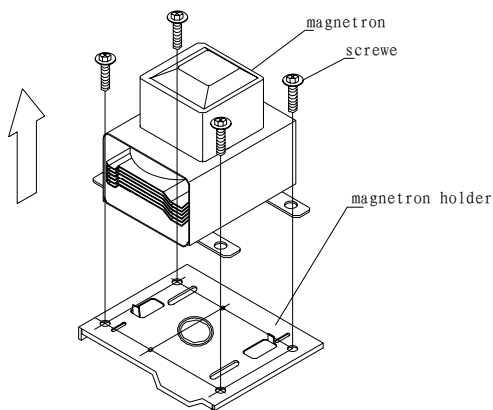

Fig. 4-7

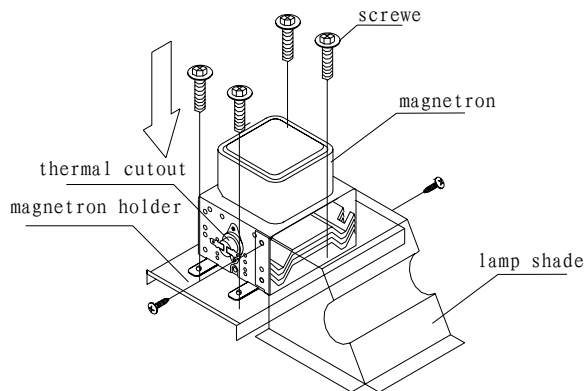

Fig. 4-8

To assemble the magnetron,

1. Check whether the copper filament weaved washer of the magnetron antenna has been placed well. It should not be fixed if there is no copper filament weaved washer, for it may cause the magnetron and the oven can't earth well, and cause large amount of microwave leakage. Attention : When a new oven matches a magnetron, the meatl lustre at “★” mark should be polished with a sand paper (FIG.4 -7).
2. Aim the head of the magnetron antenna to the hole of the wave guide housing, tighten the four screws of the

magnetron vertically, and also tighten the screws of the lampshade (FIG.4 - 8).

3. Plug in the two terminals of the magnetron filament and the thermal cutout.

#### 4.5 THE TRANSFORMER.

Firstly, do as the 1,2,3, steps at III of this part.

Dismantling steps for the transformer: (as FIG.4 -9).

1. Pull out all the terminal of the transformer.
2. Turn the microwave over.
3. Take off the right baseboard with the transformer after loosened the four screws, which fix the board on the oven. (4-10).
4. Take off the four screws, a, b, c, d with a "+"- screwdriver.
5. Take off the right baseboard, the seat and the rubber space between the transformer and the oven.

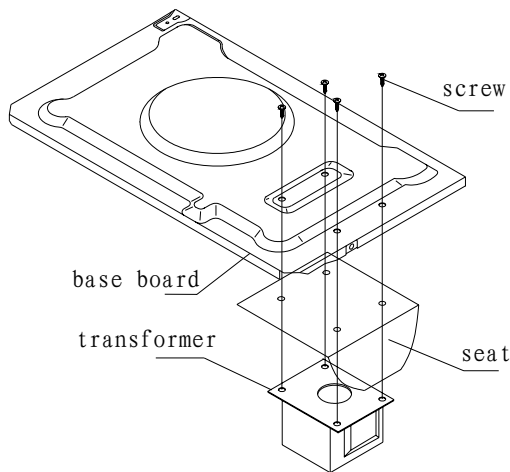

Fig. 4-9

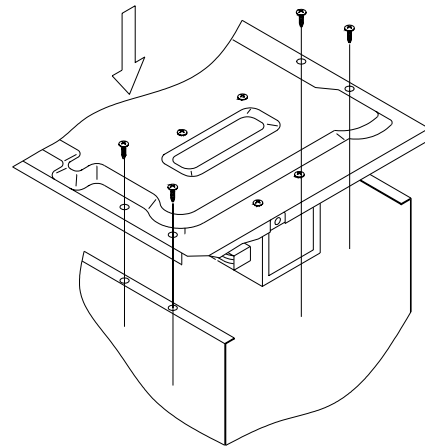

Fig. 4-10

to mount the transformer,

1. Place the transformer as the FIG.4 - 9, tear off the protective paper of the rubber lining tape, stick it on the transformer as shown on the figure. Then put on the seat and the right base board, make sure the screw hole are tallied, then tighten the four screws for the high voltage winding is earthing here.
2. Fix the transformer on the oven as FIG.4-10.tear off the protect paper of the rubber spacer, set it between the transformer and the oven, make sure the adhesive side is stucked on the oven.
3. Plug in all the terminals of the transformer precisely.

#### 4.6 THE FAN MOTOR.

Firstly, do as the 1, 2, 3, steps of III of this part.

To disassemble,

1. Pull out the two terminal of the fan motor (FIG. 4 -11).
2. According to the FIG.4 -12, pull out the lead plug which marked "A" and "C" from the thermal cutout and the fuse housing separately, and take off the earthing screw which marked "B" (FIG.4 -12).
3. Take out the power supply cord from the trough as the figure shows.
4. Loosen the screws shown on the FIG.4 -13 with a "+" - screwdriver, and take off the fan holder.
5. Take off the fan from the fan motor shaft as FIG.4 -14, then the fan motor.

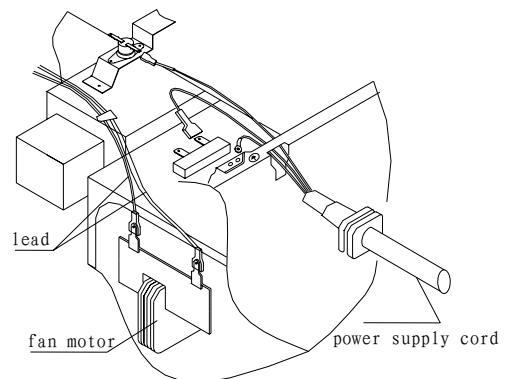

Fig. 4-11

to mount the fan motor,

1. Assemble the fan motor as FIG.4 – 14. Drip the glue on the “★” place of the fan motor shaft, and fix the fan on the motor, make sure it must be fixed to the bottom of the shaft. Attention: The fan motor shaft should not be curved, the fan should have no abnormal stick up. After assembled, check whether the running fan would knock the fan holder.
2. Assemble the fan holder as FIG.4 – 13, Then connect the power supply cord with the two wires of the fan motor, and tighten the screws as FIG.4 – 11 and FIG.4 – 12.

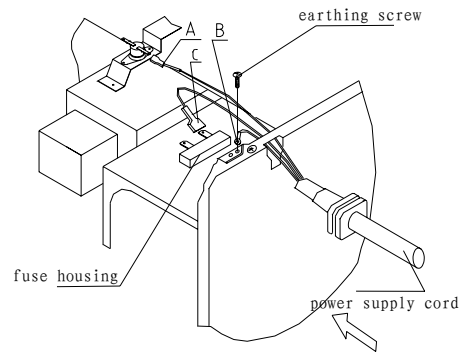

Fig. 4-12

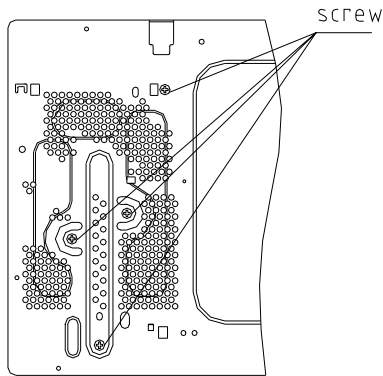

Fig. 4-13

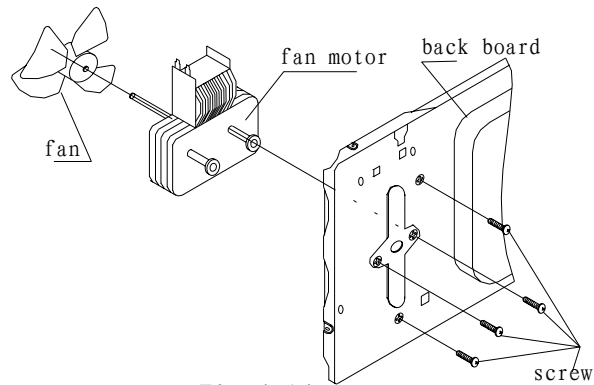

Fig. 4-14

#### 4.7 THE CAPACITOR.

Firstly, do as the 1, 2, 3, steps of III of this part.

To disassemble,

1. Pull the wires of the capacitor out (4-15).
2. Loosen and take out the screw which fix the capacitor clip with a “+” – screwdriver, and take out the clip and the capacitor. (4-15).

To assemble,

1. Place the capacitor in the capacitor clip with the end which have three foot near the diode (4-16).
2. Insert one end of the clip in the fan holder trough (FIG.4-15).
3. Tighten the screw, which fix the capacitor clip.
4. Plug in all the plugs of the capacitor.

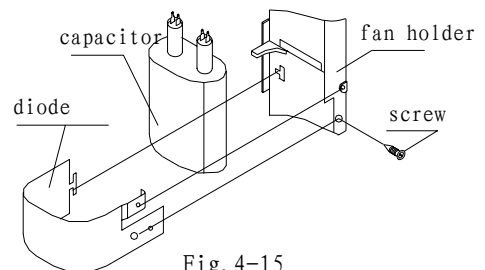

Fig. 4-15

#### 4.8 THE DIODE.

Firstly, do as the 1, 2, 3, steps of III of this part.

To disassemble,

1. Pull out the diode plug, which plugged in the capacitor.
2. Loosen the screw, which fixed the diode, and take the diode off.

To assemble,

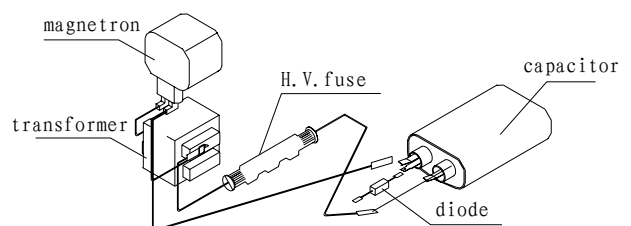

Fig. 4-16



1. Insert one end of the diode to one feet of the capacitor's connect piece.
2. Fix the diode with one screw (pay attention to the polarity of the diode, refer to FIG.4 - 16).

#### 4.9 THE TURNTABLE COMBINATION.

Firstly, do as the 1, 2, 3, steps of III of this part.

To disassemble,

1. Turn the microwave oven over (FIG. 4- 17).
2. Take off the two screws which fix the middle base board with a “+” – screwdriver and take off the middle cover (FIG.4 - 18).
3. Loosen out the two screws of turntable motor with a “+”- screwdriver, take out the turntable motor and pull out the two wires (4 -17).

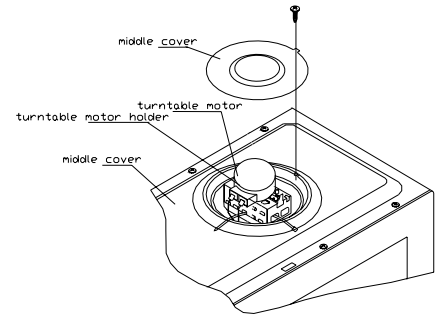

Fig. 4-17

Assembling steps:

1. Put the motor shaft into its connecting hole, and fix the motor with two screws (FIG.4 - 17).
2. Plug in the two wires.
3. Assemble and fix the middle base board with two screws (FIG.4 - 18).
4. Turn the oven back.
5. As the FIG.4 – 19 shown, fix in the turntable shaft supporter, the place in the roller ring and the glass tray as FIG .4 – 20.

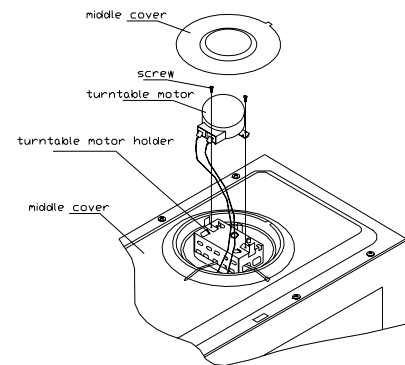

Fig. 4-18

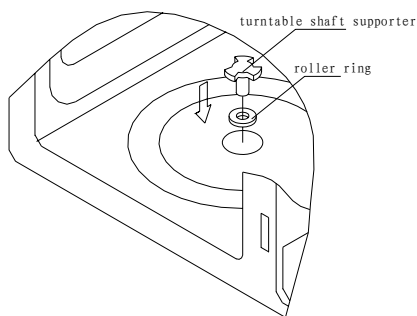
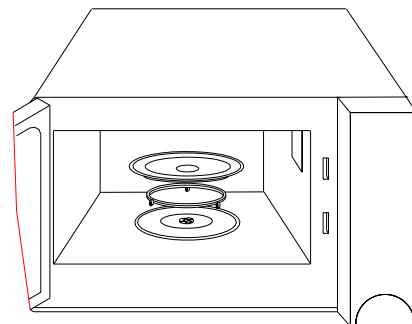

Fig. 4-19



#### 4.10 THE DOOR SAFTY INTERLOCKS.

Firstly, do as the same with 1, 2, 3, steps of III of this part.

Steps for dismantling:

- (1) Pull out the terminal plugs of the interlock switch and the pilot switch.
- (2) Loosen out the two screws which fixed the switch holder with a “+”- screwdriver, and take the switch holder off.
- (3) Take off the interlock switch and the pilot switch from the holder.
- (4) Take off the switch connecting lever arm and the working lever from the holder.

Assembling steps:

- (1) Slip on the connecting lever arm and the working lever into the switch holder.
- (2) Assemble the interlock switch and pilot switch to the switch holder, make sure they are assembled correctly.
- (3) Tightly fix the holder with two screws.
- (4) Check the position of the hook and the switch holder. Close the door, push and pull the low and up part of the

door to check whether the door is flexible. If it does, back and front position of the holder should be adjusted. Provided the up hook is loose, the door should be pushed more closely to the oven, and pull the holder inside closely after loosen the screw which fix the holder, then, tighten the screw and check whether it is still loose. If it is not or the loose is minor, it would be OK. Open the door, then close it lightly, check whether the hook is in position, if not, readjustment is needed. If the loose is at lower part of the door, the adjust methods is the same with the above said steps but the screw is the one below (FIG.4 - 21).

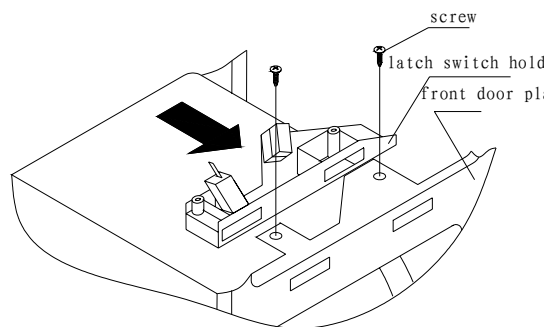

Fig. 4-21

#### 4.11 THE CONTROL PANEL OF A TYPICAL MICROWAVE OVEN

Pull out the power plug.

Take off the cabinet.

Discharge between one end of the capacitor and the baseboard with a screwdriver.

Means of dismantling the PC board and door release mechanism:

- (1) Pull out all the terminal plug of the PC board.
- (2) Loosen out the two screws which fix the control panel with a "+"- screwdriver (FIG.4 -6).
- (3) Take off the control panel.
- (4) Take off the three "+"- screws which fix the PC board as the FIG.4 - 22.

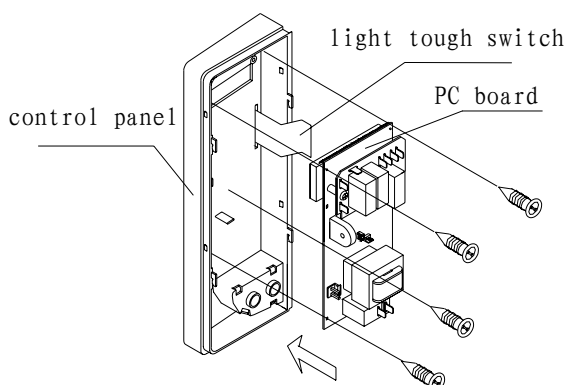

Fig. 4-22

- (5) Take off the range terminal plugs as FIG.4 - 24 shown, that is press the two places according to the arrow direction at the figure, while pull it up about 2mm, then off the row plastic board.

- (6) Take off the PC frame.

- (7) Tear off the undried glue of the light touch switch (FIG.4 - 23).

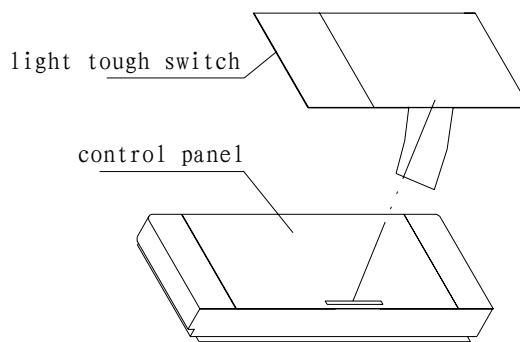

Fig. 4-23

to assemble the PC board and door release mechanism,

- (1) Tear off the undried glue patch of the light touch switch (1) and (2) as the Fig.shown, and place them into the rectangle hole of the surface of the plastic board.

- (2) After uprighted the light touch switch, tear off the protective paper on the back, and stick it on the plastic board smoothly.

- (3) Tear off the protective paper of the light touch switch (2), and stick the switch on the back of the plastic board smoothly.

- (4) Assemble in the PC frame and PC board as FIG .4 -22, and fix them with three "+"- screws.

- (5) Fix the range wires as FIG.4-24, the means are: Insert the range wires first, make sure that its notch is tallied with the flange of the row seat, then, press it down to its normal position.

- (6) Fix the control panel on the oven (FIG.4-6).

- (7) Plug in the terminal plugs of the PC board.

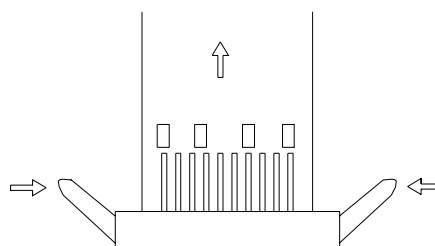

Fig. 4-24

## 5. BREAKDOWN ANALYSIS AND THE MEANS OF OVERHAULING

Before overhauling a microwave oven, you should judge the breakdown and the cause correctly, then you can repair it with corresponding ways. The overhauling must be proceed in order, any hasty conclusion is not recommendable, otherwise over-working would be done when repair. The microwave oven may occur compound breakdown due to all kinds of different reasons, thus, when overhaul, they all should be taken into consideration. Special attention must be given to the microwave leakage and the electric insulation when examine because they may do harmful to the repairing staff.

### 5.1 EXAMINING THE BREAKDOWN CAUSES.

How to examine a microwave oven with breakdown? A better means which demonstrated in practical operating are through inspecting and listening. On the basis of large amounts of perceptual knowledge, you can judge and analysie the break down quickly and correctly.

#### 5.1.1 INSPECTION.

Inspect whether the oven shape is disordered and where is the disordered position, If any. It is normal if the cabinet disordered a little, but abnormal if the oven, the door disordered, the door hook broken, the door crooked, or there are too much looseness between the door and the oven after the door is closed .

#### 5.1.2 LISTENING.

Listening to the sound of the oven operating and the noise of the fan. Minor “wen wen” noise, cycling“kala”noise and “shishi” noise should be considered as normal. But it is abnormal if the following noises occur:

- (1) Sound “wen wen ” noise.
- (2) Long time “shishi” noise.
- (3) Strike sound like “Pipa pipa”

### 5.2 SPOT EXAMINING STEPS OF THE MICROWAVE OVEN

#### 5.2.1 EXAMINE THE MICROWAVE INSULATING RESISTANCE

Measure the insulating resistance with a avometer or a megaohmmeter the value should not be less than 2 megaohms. Otherwise, part examination should be taken at once. Such as checking whether the motor, the thermal cutout, the transformer or the capacitor are electricity leaking.

#### 5.2.2 EXAMINATION OF THE RESISTANCE VALUE OF THE MICROWAVE OVEN.

Close the door, set the time (the oven is at operating condition but the power plug haven't been plugged in ), measure the two feet (L - N) of the power plug with R×1 grade of an avometer, the resistance value should be about 2.5 ohm. If open circuit occurs, then you must check whether the 8A fuse is broken、 the primary winding of the transformer is open circuit、 the thermal cutout is open circuit or not, you must check whether the interlock device is put through or all the plugs are connected well. If short circuit occurred or the resistance less than 1.5 ohms, you should check whether the primary winding of the power transformer is short – circuited or part short – circuited.

#### 5.2.3 EXAMINATION OF MICROWAVE LEAKAGE.

Measure the microwave leakage with a microwave leakage measure. Place a graduate of 275ml water at the middle of the glass tray of the oven (FIG.5 - 1). Close the door, power set high, time set to 3 minutes, press the starting button to operate the oven. After rectified the microwave leakage measure, measure around the door crack, those hole position of the window and the air vent at four sides of the oven with the probe of the measure. When measure, the moving

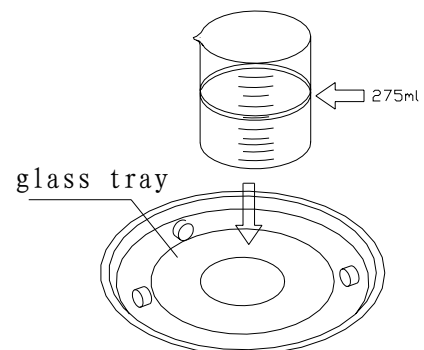

Fig. 5-1

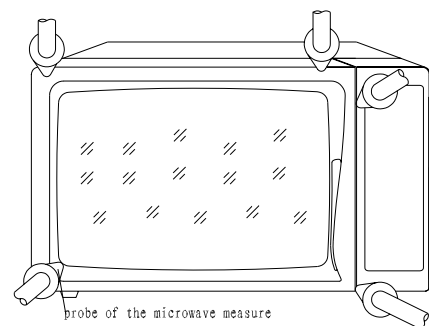

Fig. 5-2

speed of the probe should not exceed 25mm per second, and the measuring direction should be the same with the outing direction of the probe should not exceed 25mm per second, and the measuring direction should be the same with the outing direction of the microwave leakage (FIG.5 - 2)..

When measuring the ultimate value of microwave leakage of all the measure position should not exceed 1 milliwatt/cm<sup>2</sup>, of should be considered as abnormal.

**5.2.4 EXAMINE WHEN THE OVEN AT OPERATING, BUT THE FOOD CAN'T BE HEATED.**

(1) Examine when the lamp is on, the glass tray is cycling, the fan operating in normal:

Take off the cabinet, starting the oven, measure the plug of the transformer with an avometer to see whether it is enough to 120V. If it is enough to 120V, then the secondary high voltage of the transformer should be examined as FIG.5 – 3.

Measure it with the 2500V-alternating grade of model 500 avometer. One rod of the avometer connects the iron core of the transformer, the other rod connects the secondary high voltage plug (FIG.5 - 4). The avometer reading should be about 2100V (when measure, be careful with the high voltage). If no voltage

at all, it indicates that the transformer has broken, and should be replaced by a new one. If it is enough to 2100V, then check the filament voltage of the transformer with alternating 10V grade of an avometer, the value should be about 3.4V (FIG.5 - 5).

If there is no voltage at all, it indicates the transformer has broken, and should be replaced by a new one. If it is enough to 3.4V, check the filament resistance of the magnetron, measure the filament plug with the R×1 grade of a avometer (FIG.5 - 6). If it is open – circuited, it indicates the magnetron has broken, and should be replaced by a new one. It is normal if the resistance very small. Then check whether the magnetron steel has broken, if broken, replace with a new magnetron.

If there is no problem with the magnetron, check the high voltage diode then. Measure the diode with R×10K grade of an avometer, the “+” rod end of the avometer connect the cathode of the diode, the “-” rod end of the avometer connect the anode of the diode (FIG.5 - 7).

The avometer reading should be about 150 thousand ohms. The change the rod to different electrode, the reading should be “∞” . If the reading is very small, and near to short circuit, it indicates the high voltage diode has been punctured, and should be replaced by a new one.

If the high voltage diode is OK, then check the forwarding plug of the transformer to see whether it is enough to 120V. If it is not enough, check the micro – switch of the time and power distributor. Connect the two rods of the avometer to the 1,2 place of the timer with R×1K grade. It is normal if the reading is “0” when at cut off condition. If the reading is “∞” , it indicates the micro switch has broken, and the timer should be replaced by a new one. If all the above examination shows normal ,then check whether the terminal plug of the magnetron and the capacitor have loosened, if it is loosened, pinch it tightly with a pliers.

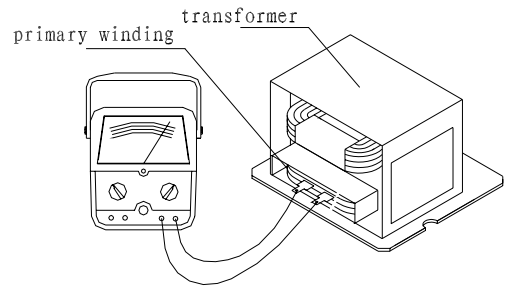

Fig. 5-3

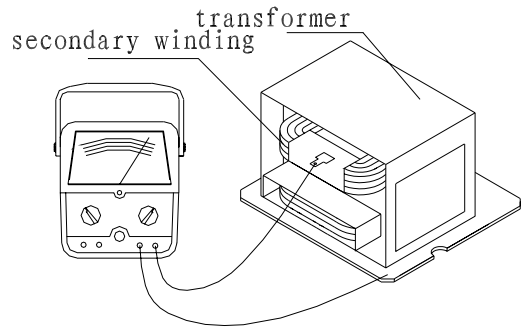

Fig. 5-4

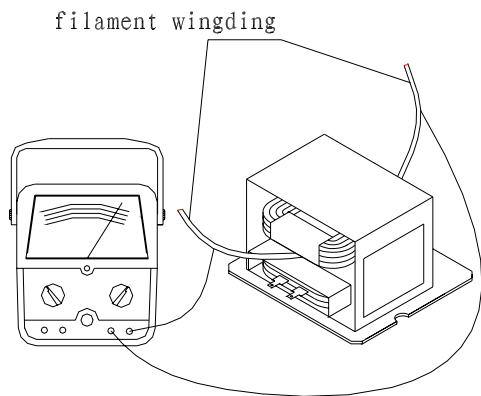

Fig. 5-5

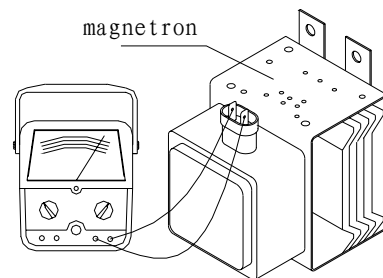

Fig. 5-6

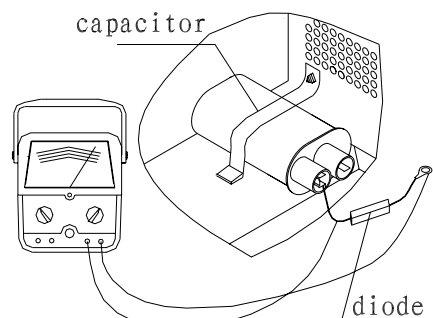

Fig. 5-7

### 5.2.5 EXAMINE THE STARTING AND THE 8A FUSE OF THE MICROWAVE OVEN.

Pull out the power plug, take off the cabinet, discharge the capacitor, measure the resistance value of the primary winding and the secondary winding of the transformer with an avometer (FIG.5 – 10 and FIG.5 - 9). The resistance value of the primary winding should be about 2.2 ohms, the secondary winding should be about 130 ohms. Otherwise, it indicates the transformer has broken, and should be replaced by a new one.

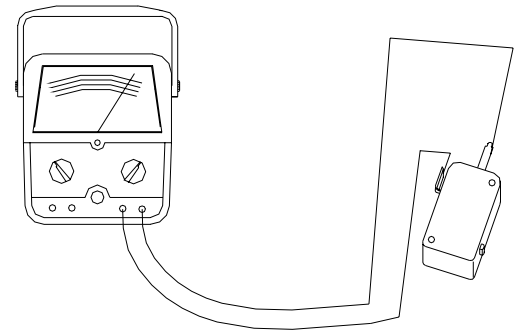

Fig. 5-8

If the transformer is normal, then the high voltage capacitor should be checked. Pull out the connecting plug of the capacitor, and measure it with R×1 grade of an avometer, the two rods of the avometer connect the two polarity of the capacitor. When they just connected, the reading of the avometer should be zero, then increases to nine megaohm slowly. Change the rod to different polarity, the reading repeat from zero to nine megaohm (FIG.5 - 11), it means the capacitor is normal. If the indicator of the avometer can't point out from zero to nine megaohms, it indicates the high voltage capacitor has broken, and should be replaced by a new one.

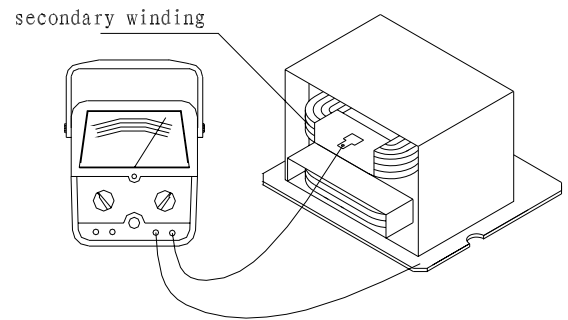

Fig. 5-9

If it is normal between the two pole of the capacitor, then the insulation between the capacitor pole and the cabinet should be measured with R×10K grade of an avometer. The resistance value should be "∞" (FIG.5 - 12). If it is short circuited or have a number reading, it indicates that the capacitor has been punctured or electricity leaked, and should be replaced by a same model, same capacity one.

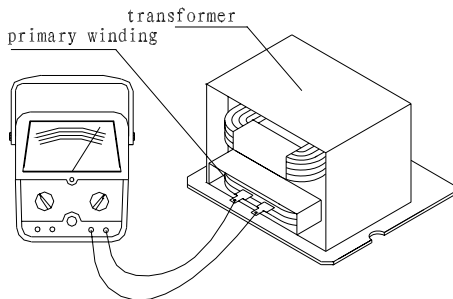

Fig. 5-10

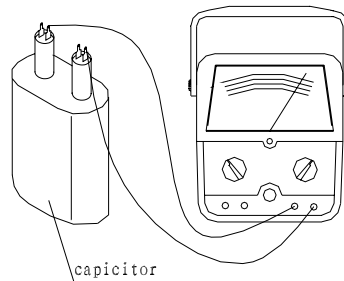

Fig. 5-11

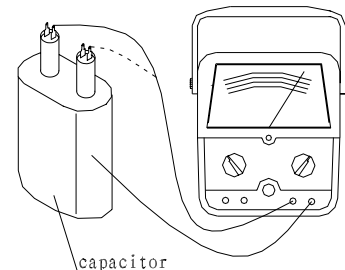

Fig. 5-12

If the resistance value of the capacitor's two pole are "∞" , the capacitor is normal. Then check the earth of the magnetron's two filaments to see whether they are short – circuited (FIG.5 - 13). If they are short – circuited and the filament strikes the shell of the magnetron, it indicates the magnetron has broken, and should be replaced by a new, same model one.

If the magnetron is also normal, then test the pilot switch. Pull out the two plugs of the switch. Measure it with the R×1 grade of avometer, the two rod connect the plug of the switch, the resistance value should be "∞" (FIG.5 - 8).

Then press down the pilot switch with a screwdriver, if the reading of the avometer pointed to zero, it indicates the pilot switch has broken, and should replace it with a new, same model one.

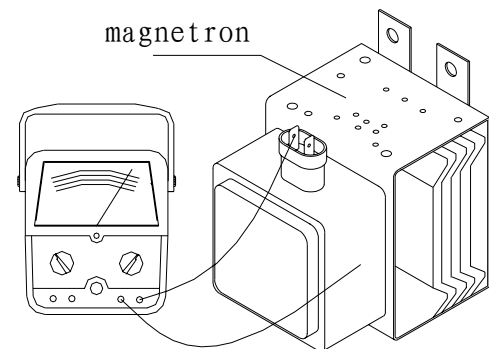

Fig. 5-13

### 5.3 REPAIRING METHOD OF SEVERAL BREAKDOWN

1. Repair when there occurred large amounts microwave leakage. There are many factors which may cause microwave leaking. Following mentioned may be the main causes of microwave leakage:

- (1) The door deformed, the hinge loosed or damaged that caused the door can not close tightly.
- (2) The door pressing cover or the embed piece damaged or come off.
- (3) Obvious damage or uneven of the oven.
- (4) There are filth between the door and the oven.
- (5) The door and the oven are serious loosed after the door closed.
- (6) The crack of the door shielding net cover.

Before repairing, check whether the above listed point are existed, if not, can you start the microwave oven. Place a graduate of about 275ml water at the middle of the glass tray, close the door, time set at 3 minutes, power at high, make the oven operating in normal. Rectify the microwave leakage measure, measure the amount of the microwave leakage around the oven with its probe. If there are places which the leakage exceeds the standard requirement, then repair them accordingly. If the leakage amount exceeds 1 milliwatt/cm<sup>2</sup> at the left door crack, then pull out the power plug, take down the cabinet, adjust the screws of the hinge (up and low) as figure5-14 to less the gap between the door and the oven. Then measure again, the leakage amount should be less than 1 milliwatt/cm<sup>2</sup>. Generally, it should be controlled below 0.75 milliwatt/cm<sup>2</sup> with some allowance.

If the leakage occurred at the right door crack, adjust the screws which fix the interlock holder and the hook. If the leakage is the larger side at the right – above of the oven, then adjust the upper screw as FIG.5 – 15. Loosen out the screw, push the door close to the oven to hook the door hook with the plastic parts, then tighten the Screw again. If the leakage is larger at the right – below, then adjust the lower screw as FIG. 5 – 15. Loosen the screw, push the door close to the oven to hook the door hook with the switch holder tightly, then tighten the screw again, and open and close the door repeatedly, to check whether the door can operate flexibly, whether the hook and the switch are in their normal position. If it is not in position, then adjust the door hook and the switch holder repeatedly to make them to normal position, to put through the interlocks, to cut off the pilot switch, to less the loose between the door and the oven, then measure the leakage with microwave measure again.

If the leakage still exceeds standard requirement, then inspect whether the right oven is even or not, if not, smooth it. Then adjust the door and the oven to eliminate their loose to the ultimate.

If there still exist microwave leakage, measure near the magnetron with the probe of the microwave leakage mea-sure. If the leakage is larger, the oven should be turned off and check whether the four screws which fix the magnetron have been loosed, if loosed, twist them tightly with socket wrench. If the four screws are fixed, then the magnetron should be taken down to check the copper filament weaved washer of the magnetron has been placed well or whether the wave guide housing coupling has been oxidized or have lacquer on it. If do have, scrape the oxidized layer or the lacquer off. When fix the magnetron, the copper filament weaved washer must be placed well, the screws must be twist tightly. Then turn on the oven and measure again until it comply with the requirement. If

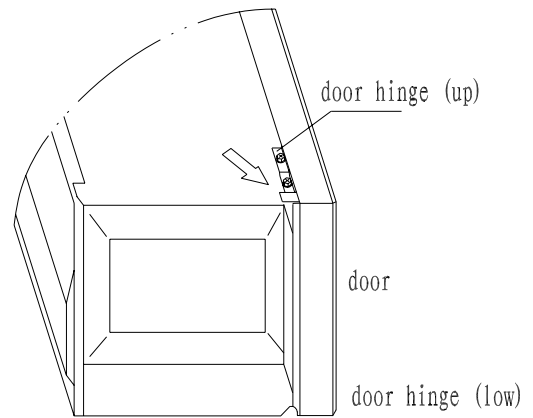

Fig.5-14

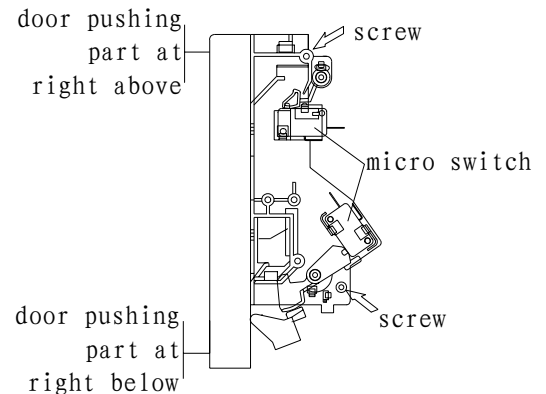

Fig. 5-15

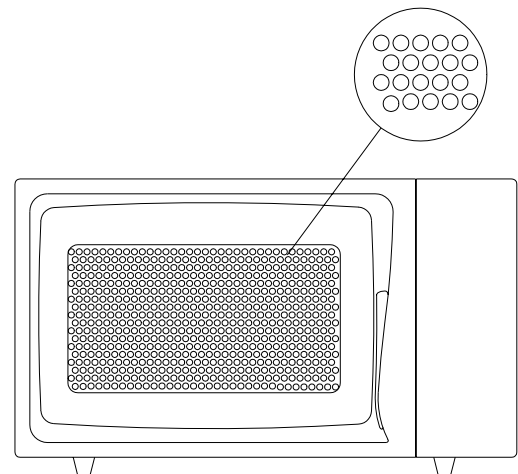

Fig. 5-16

the microwave leakage is larger at those hole position of the window board. The oven should be turned off to inspect whether there are crack among them (fig.5 - 16). If several holes formed a crack, it would enlarge the microwave leakage. If that is the case, it indicates the door has broken, and should be replaced with a new door.

#### 2. Means of repair when the oven can heat, but the turntable glass can't move

Firstly, check whether the turntable holder is placed correctly. If it is correct, then pull out the power plug and take down the turntable combination, measure the resistance value of the turntable motor R×1K grade of a avometer. If it is open – circuited, it indicates the turntable motor has broken, and should be replaced by a new, same model one. If the resistance value is between 15 –22 K, it indicates the turntable motor is normal. Then check the connecting shaft weave. If the plastics which the shaft insert in has broken, a new shaft weave should replace it .

#### 3. Repair when the oven can heat, but the lamp is not on.

Pull out the power plug, take down the cabinet an discharge the capacitor.

Pull out the two terminal plugs of the lamp. Measure the two plugs of the lamp with the R×100 grade of a avometer.

If it is open – circuited, it indicates the lamp has broken, and should be replaced by a same model one.

#### 4.Means of repair when the oven stop working after several minutes operating.

The phenomenon indicates the thermal cutout is playing its protective role, and you should check whether the fan is working in normal. Turn off the oven, pull out the power plug, take down the cabinet, discharge the capacitor, then turn the fan with hand to see whether it is moving flexibly. If not, it indicates that the oil bearing of the fan motor has run off the oil, and should take down the fan combination to repair the motor. Loosen the two screws which fix the bearing out the shaft and the bearing, and rinse them with kerosene (ATTENTION: The bearing can only be wiped with a silk which moistened with kerosene rather than be washed in the kerosene because there are felt on it. If the felt are soaked with kerosene, then the engine oil can not be sucked up. ). After the bearing being cleaned, the felt should be refueled fully with engine oil (for when the oven is operating, the engine oil empty into the oil bearing slowly). Fix the bearing cover with two screws, turn the fan around till it can move flexibly. Then install them to the oven, and plug in the two terminal plugs.

If the fan can move flexibly, then the winding of the fan motor should be examined. Measure the winding with R×100 grade of a avometer, if it is open – circuited, it indicates the winding of the fan motor has broken, and should be re-placed by a new, same model one.

### **5.4 THE CHARACTERS REQUIREMENTS OF MICROWAVE AFTER IT HAS BEEN REPAIRED**

After being repaired, the microwave oven should have a 30 minutes trial operation. It can be used only when it has been demonstrated that it is in good conditions of safety, heating and defrosting. The oven must have the following identifications when it at trial operating:

#### **5.4.1 INSULATION:**

Before conducted, measure the insulation resistance among those electric metal parts and the nonelectric metal cabinet with a 500V.D.C. Megaohmmeter. The resistance value should not be less then 2 megaohm.

Testing condition: Door closed, power at “high”, time set at 3 minutes. This is the operating condition of the oven, but the power plug is not connected.

#### **5.4.2 MICROWAVE LEAKAGE:**

Microwave leakage can not be tell by watching or touching. To be responsible for the user, the amount of microwave leakage should be measured strictly, and should not exceed 5 milliwatt/cm<sup>2</sup>, according to the IEC STANDARD. Some countries stipulate that the maximum microwave leakage should not exceed 1 milliwatt/cm<sup>2</sup>. For safety concern, we must control the leakage under 1 milliwatt/cm<sup>2</sup> after the oven being repaired, otherwise, it should be repaired again. Test must be proceeded completely and comply with the following procedures:

Put a graduate of about 275ml water at the middle of the turntable glass tray of the oven, insert the power plug, close the door, power set high, time set 3 minutes to make the oven in operation. Rectify the microwave leakage measure first, measure around the door crack the metal net of the door and the air vent with the probe of the measure when measuring, the moving speed of the probe should not exceed 25mm/sec. The measuring direction of the probe must be the same with the outgoing direction of the microwave leakage.

#### **5.4.3 MICROWAVE HEATING.**

Place a graduate of about 250ml water on the turntable tray. Close the door, power set high, time set 4 minutes

(To those 700W microwave oven) to make the oven operating in normal. When the bell of the timer rings, open the oven door, the water should have boiled. If it have not been boiled yet, but is very hot, check whether the voltage is less than 120V. If the voltage below 120V but the water can be boiled after a little more time beating, it is normal.

#### **5.4.4 MICROWAVE DEFROST:**

Place a graduate of about 200ml water on the turntable glass tray of the oven, power set middle, time set 4 minutes to make the oven operating in normal. When the bell of the time ring, open the door. It would be normal if the water is lukewarm.

## **6. CRITICAL PARTS SERVICING**

### **6.1 IMPORTANT THINGS TO DO PRIOR TO CRITICAL PARTS SERVICING:**

The following instructions are CRITICAL to the owner's safety. Be sure to follow all the instructions. Contact the manufacturer or distributor if you have any question.

1. If the oven is operative prior to servicing, a Microwave Leakage Test (a. k. a. Microwave Emission Check) should be performed prior to servicing the oven Refer to Section 7.3, Microwave Leakage Test. For the detailed check procedures.
2. In the event that any microwave oven found to have microwave emission level in excess of 4 mW/cm<sup>2</sup>. The following procedures should be followed:
  - (1). Inform the distributor; importer, or manufacturer the finding. Record it in the logbook as well.
  - (2). Repair the unit at no cost to the owner.
  - (3). Investigate the oven and ascertain the cause of the excessive leakage.
  - (4). Hold the oven in your facility and instruct the owner not to use the unit until the oven has.
3. In the event that the oven operates with the door open. The following procedures should be followed:
  - (1). Tell the user not to operate the oven.
  - (2). Hold the oven in your facility until it is investigated and repaired.
  - (3). Contact the manufacturer and CDRH (FDA) immediately.

### **6.2 INTERLOCK ASSEMBLY REPLACEMENT AND ADJUSTMENT.**

1. If you suspect defective primary, secondary or monitor interlock switches, use your ohmmeter (digital or analog type) to check the electrical continuity.
2. Make sure the power cord is pulled out and the high-voltage capacitor is discharged before the electrical continuity check.
3. Set the ohmmeter to "Low Resistance" range and connect both leads (alligator clips) to the switch terminals.
4. Open the door and notice the meter reading the primary or secondary interlock switch should show an "infinite" resistance when the door is open. Replace it when it is defective. The monitor interlock should show a "zero or near zero" resistance when the door is open. When the door is closed, the readings will be opposite.
5. If the oven has been rendered inoperative due to the failure of the monitored safety (primary and /or secondary ) interlock(s). You should replace all of the monitored safety interlock switched and the monitor switch.
6. Refer to Chapter 4, Sections I and X for how to remove and assemble the interlock and monitor switches.
7. Always refer to Section 0.4 for adequate wiring diagram. Monitor interlock must always be installed. Repeat Step 6.2.4 to check electrical continuity.
8. Perform required checks and tests as described in Chapter 7 before releasing the oven to the owner.



## 7. COMMON BREAKDOWN OF MICROWAVE OVEN AND MEANS OF REPAIRING

PHENOMENON	CAUSE	REPAIRING MEANS
1. When starting the oven, the lamp is not on, the turntable tray can't rotate and the food can't be heated	<p>8A fuse broken.</p> <p>The primary and secondary winding of the transformer are short – circuited.</p> <p>The earthing or the polarity of the polarity of the capacitor is punctured.</p> <p>The pilot switch can't cut off.</p> <p>The interlock switch hasn't closed.</p> <p>The power plug and the socket are not in good connection.</p> <p>The door hook broken.</p>	<p>Change a new fuse.</p> <p>Change a new transformer.</p> <p>Change a new capacitor.</p> <p>Change a new pilot switch.</p> <p>Change a new interlock switch.</p> <p>Adjust the connection or replace it by a new one.</p> <p>Change a new hook.</p>
2. When starting the oven, the lamp is on, the turntable rotating, the fan cycling but the food can't be heated.	<p>The primary and secondary winding, the filament of the transformer are open – circuit-ed.</p> <p>The magnetron filament is open – circuited, the magnetic steel of the magnetron broken or the magnetron is air leaking.</p> <p>Time and power distributor broken.</p> <p>The plugs of the magnetron or the capacitor loosed.</p>	<p>Change a new transformer.</p> <p>Change the magnetron.</p> <p>Change the time power distributor or the micro-switch.</p> <p>Fix them.</p>
3. The food can be heated, but the lamp is not on	<p>The lamp broken.</p> <p>The plug falls off.</p>	<p>Change a new lamp</p> <p>Insert the plug again</p>
4. The food can be heated but the turntable tray is not rotating.	<p>The turntable motor broken</p> <p>The plug fall off</p> <p>Connecting shaft weave broken</p>	<p>Change the turntable motor</p> <p>Inset the plug securely</p> <p>Change the weave</p>
5. The oven can heat within 2-3 minutes, but can not heat from the fourth minutes	<p>The winding of the fan motor in open-circuited.</p> <p>The fan falls off</p> <p>The plug of the fan motor falls off</p> <p>The turntable shaft is griped with the mo-tor bearin</p> <p>The cooling vent blocked</p>	<p>1.Change the fan motor</p> <p>2.Change the fan</p> <p>3.Insert the plug</p> <p>4.Overhauling them</p> <p>5.Repairing it</p>
6. When starting the oven, it can't heat, and with "wenwen" noise.	<p>The high voltage diode was punctured</p>	<p>Change a new diode</p>
7. The oven can heat, but with sound "shishi" noise	<p>The iron core of the transformer loosed</p>	<p>Change a new transformer</p>
8. Large amount of microwave leakage	<p>The door deformed</p> <p>The door metal net cracked</p> <p>The gap of the door crack is too large</p> <p>The welding point of the oven falls off</p> <p>The screws which fix the magnetron loosed</p> <p>The wave guide connection oxidized</p> <p>The magnetron copper filament washer is too thin cause the wave guide opening not in good earth.</p>	<p>Mend the door</p> <p>Change the door</p> <p>Adjust the gap</p> <p>Change the oven</p> <p>Tighten the screws</p> <p>Scrape the oxidized and tighten the screws</p> <p>Thick the copper filament washer</p>

9. The door can't open	After long time using, the wear and the rust –eaten enlarged the gap of the door shaft and the shaft hole, thus cause the door crooked. The door hook broken.	Adjust the hinge to rectify the position of the door. Change the hook.
10. The door release button fall off	Worn out and aged after long time operating	Overhaul it or renew it
11. Electricity leaking	The earthing insulation resistance of all the motors or the transformer are less than 2 megaohms.	Test where is the leaking place, then repair it or change those damaged components.

### SPECIFICATIONS

Power Consumption:	120V~60Hz, 1450W
Microwave Power Output:	1000W
Operation Frequency:	2450MHz
Outside Dimensions(H×W×D):	11.9×20.5×17.1 in.
Oven Cavity Dimensions(H×W×D):	8.5×13.7×15.0 in.
Oven Capacity:	1.1cu.ft
Cooking Uniformity:	Turntable System (Φ 12 3/8" )
Net Weight:	Approx. 45.2lbs.